

# KV-2585AS

## RM-687C

# SERVICE MANUAL

*Australian Model*  
Chassis No. SCC-D23L-A

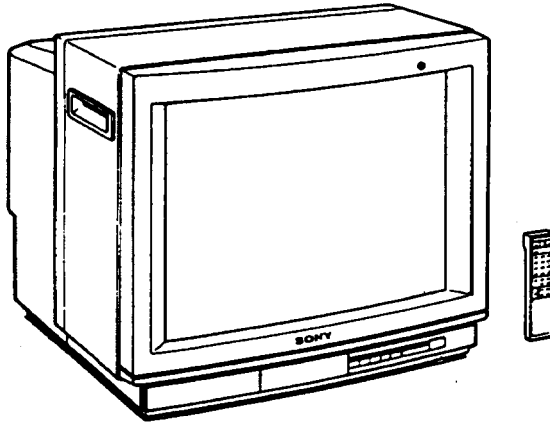

## GP-1A CHASSIS

### MODELS OF THE SAME SERIES

KV-2585AS	
KV-2584AS	
KV-2566AS/2966AS	

### SPECIFICATIONS

Power requirements  
Power consumption  
Color system

110 – 240 V AC, 50/60 Hz  
140 W  
PAL, PAL 60, NTSC<sup>4.43</sup>,  
NTSC<sup>3.58</sup>  
B/G

Audio output  
Inputs

5 W  
Antenna: 75 ohms  
VIDEO IN jacks: phono jacks  
Video: 1 Vp-p, 75 ohms  
Audio: 500 mVrms, high  
impedance

Television system

VHF 0 – 11, 5A  
UHF 28 – 69  
CATV S01 – S03  
S1 – S20

Outputs

MONITOR OUT jacks:  
phono jacks  
Video: 1 Vp-p, 75 ohms  
Audio: 500 mVrms, low  
impedance

Channel coverage

Picture tube  
Dimensions  
Mass

Approx. 64 cm (25 inches)  
595 × 528 × 470 mm (w/h/d)  
35 kg

Design and specifications are subject to change without notice.



TRINITRON® COLOUR TV  
**SONY®**

# Operating Instructions

Before operating the TV, please read this manual thoroughly and retain it for future reference.

## SECTION 1 GENERAL

The operating instructions mentioned here are partial abstracts from the Operating Instruction Manual. The page numbers of the Operating Instruction Manual remain as in the manual.

### 1-1. ANTENNA CONNECTION

To connect a VHF antenna or a combination VHF/UHF antenna — 75-ohm coaxial cable (round)

Plug the connector into the T socket of the TV.

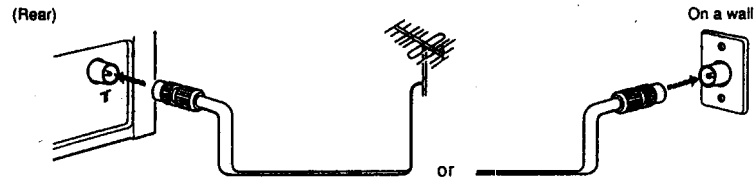

To connect both VHF and UHF antennas

1. Attach the antenna cable ends to the UHF/VHF mixer.
2. Plug the mixer into the T socket of the TV.

3

### 1-2. CONNECTING A VTR

Connecting a VTR

(Rear)

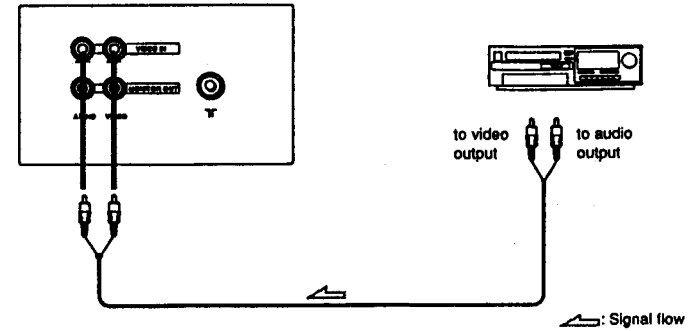

Connecting two VTRs for Tape Editing

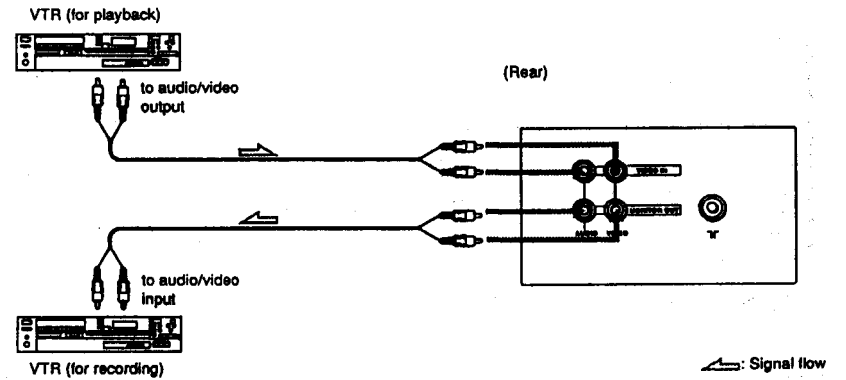

### 1-3. PRESETTING TV CHANNELS

#### Presetting TV channels automatically

You can preset up to 30 channels automatically to the program position numbers (0 to 29) in numerical sequence from channel number 1.

(Front)

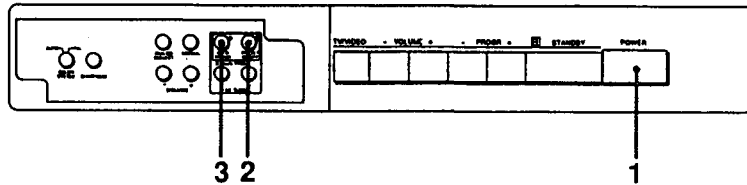

1 Press the POWER button.

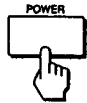

2 Press the PRESET ON/OFF button (1).



3 Press the AUTO PROGR button (2).

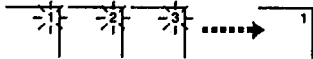

#### Manual Presetting

To change the program number for a channel, or to receive a channel of weak signal, preset the channel manually.

Example: To preset a channel in program number 8

- 1 Press the PRESET ON/OFF button.
- 2 Press the PROGR +/- buttons until "8" appears.
- 3 Press the MANUAL PROGR +/- buttons until the channel you want appears.
- 4 Press the PRESET ON/OFF button.

To preset other channels  
Repeat steps 1 through 4.

#### Skipping Program Positions

You can skip the unused or undesired program position when you are selecting a program using the PROGR +/- buttons.

Example: To skip the program position 8

- 1 Press the PROGR +/- buttons until "8" appears.
- 2 Press the PRESET ON/OFF button.
- 3 Press the NORMAL button.
- 4 Press the PRESET ON/OFF button.

To skip other channels  
Repeat steps 1 through 4.

To cancel the skip setting  
Preset the station manually as described in "Manual Presetting", or preset automatically again.

### 1-4. WATCHING THE TV

To switch on or off the TV

POWER



The TV power is turned on or turned off completely.

To select a channel

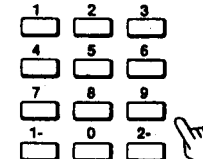

To select 8



To select 10



To select 25



or

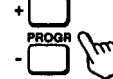

To adjust the volume

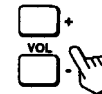

To set the TV to standby mode

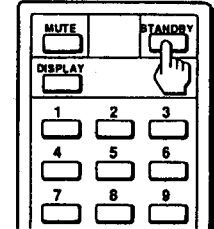

To turn on the TV, press the channel number buttons or the PROGR +/- buttons.  
Or press the TV button (only for KV-2585GET).

#### Note

You can also use the buttons on the TV that have the same function.

	Commander	TV
To turn off the TV for a short period of time	Press STANDBY.	—
To turn on the TV from the standby mode	Press channel number buttons or PROGR buttons. Or press TV button (only for KV-2585GET).	Press PROGR + or - button.
To cut off the power completely	—	Press POWER.

## 1-5. WATCHING THE VIDEO INPUT

**1** Press the TV/VIDEO button (for KV-2585AS and KV-2585GE) or VIDEO button (for KV-2585GET) on the Remote Commander.

**2** Set the VTR to playback mode.

To return to TV mode  
Press the TV/VIDEO button (for KV-2585AS and KV-2585GE) or TV button (for KV-2585GET), the channel number buttons, or the PROGR +/- buttons.

**To set COLOR SYSTEM**

**Adjusting SHARPNESS**

Normally, set COLOR SYSTEM to AUTO.  
If the color reproduction is not normal (for example, the picture turns red or blue) while receiving PAL and PAL 60 playback signal, set to PAL. The picture color will become normal.

Turn SHARPNESS clockwise to increase sharpness and counterclockwise to decrease sharpness.

## 1-6. ADJUSTING THE PICTURE

**Adjusting the Picture Quality**

**1** Select the adjustment item using the SELECT button on the Remote Commander (or ANALOG SELECT button on the TV).

**2** Adjust using the + or - button.

Contrast and color intensity      Color      Brightness      Hue (Operative NTSC signal only)

PIC IIII → COL IIII → BRI IIII → HUE IIII IIII

**To return to factory settings**  
Press the NORMAL button on the Remote Commander or on the TV.



## 1-7. USING CONVENIENT FEATURES

**Turning On or Off the On-screen Display**

Press the DISPLAY button.

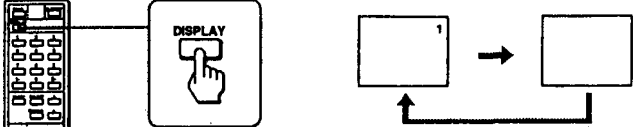

**Muting**

Press the MUTE button.

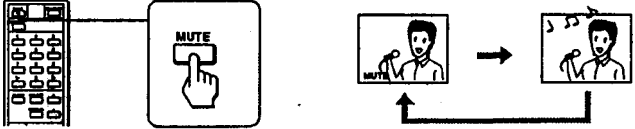

**Setting the Sleep Timer**



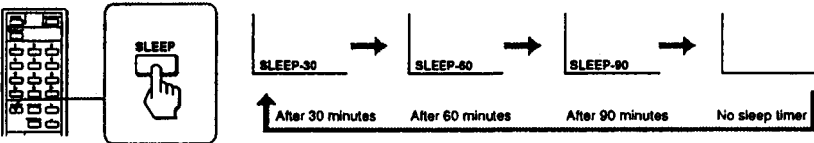



The TV will be turned off after about 30, 60, or 90 minutes.  
Press the SLEEP button.



**To cancel the sleep timer**  
Press the SLEEP button until the sleep display disappears.

## 1-8. TROUBLESHOOTING

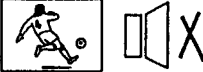
If you have any problem, check the countermeasure for each symptom listed below.  
If the problem still cannot be solved, contact your nearest service facility.

Symptom	Countermeasure
Snowy picture Noise (sound interference) 	<ul style="list-style-type: none"> <li>• Check the antenna position.</li> <li>• Check antenna/cable connections on the TV or wall.</li> <li>• Fine-tune the channel manually.</li> </ul>
Dotted lines or stripes 	This is often caused by local interference (for example, cars, neon signs, hairdryers etc.). Adjust the antenna for minimum interference.
Double images or "ghosts" 	Reflections from nearby mountains or buildings often cause this problem. Connecting a highly directional outdoor antenna may improve the picture.
No picture No sound 	<ul style="list-style-type: none"> <li>• Check the power cord connection.</li> <li>• Make sure POWER is switched on.</li> <li>• Check the antenna connection.</li> <li>• Check the VTR connections.</li> </ul>
Good picture No sound 	<ul style="list-style-type: none"> <li>• Press VOLUME +.</li> <li>• Press MUTE.</li> <li>• Check the VTR connections.</li> </ul>
No color Abnormal color 	<ul style="list-style-type: none"> <li>• Check the COLOR SYSTEM setting.</li> <li>• Adjust the color intensity.</li> <li>• This is often caused by incomplete tuning. Try presetting directly.</li> </ul>
Poor or no picture, good sound 	<ul style="list-style-type: none"> <li>• Adjust brightness, color intensity or picture contrast.</li> <li>• Press NORMAL.</li> <li>• Check VTR connections.</li> </ul>

## SECTION 2 DISASSEMBLY

### 2-1. K BOARD REMOVAL

Note : Follow the disassembly procedure in the numerical over given.

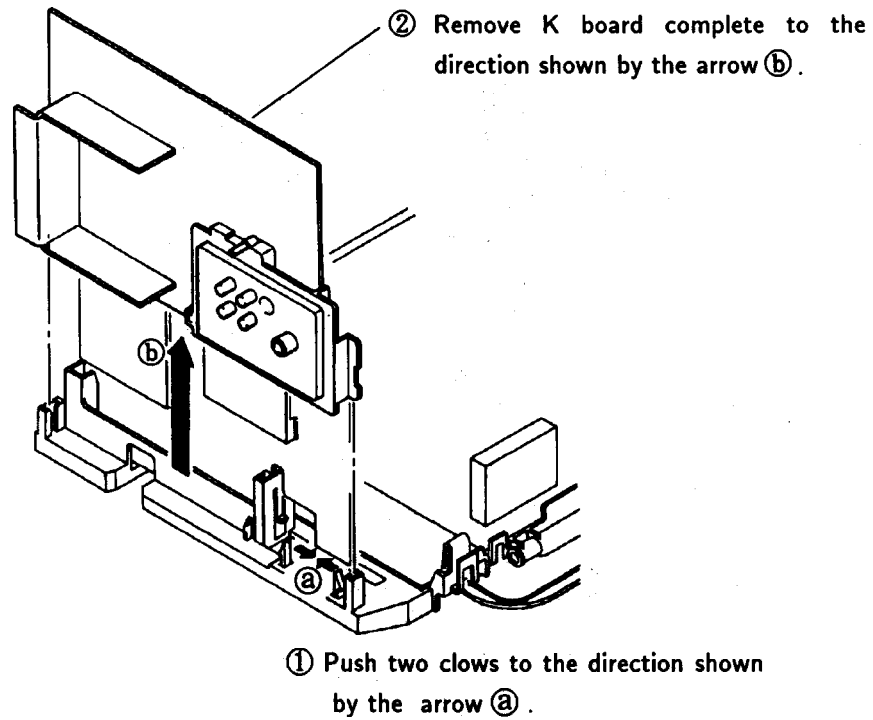

### 2-2. SERVICE POSITION FOR A BOARD

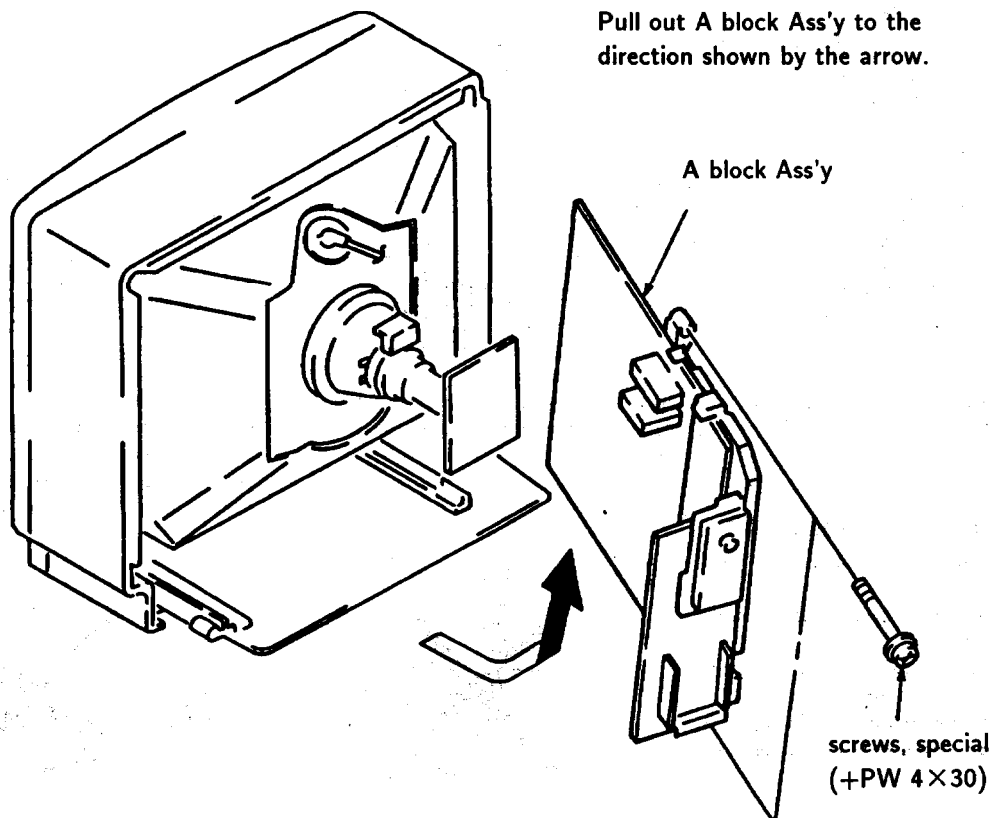

## 2-3. PICTURE TUBE REMOVAL

Note: Follow the disassembly procedure in the numerical over given.

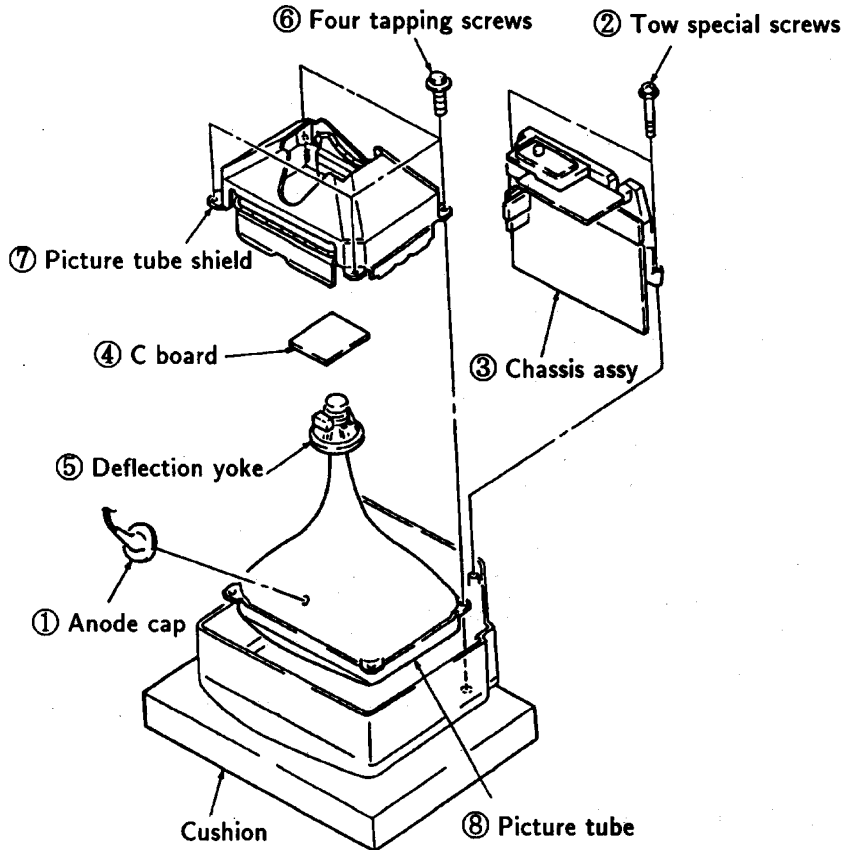

### • REMOVAL OF ANODE-CAP

NOTE: Short circuit the anode of the picture tube and the anode cap to the metal chassis, CRT shield or carbon painted on the CRT, after removing the anode.

#### • REMOVING PROCEDURES

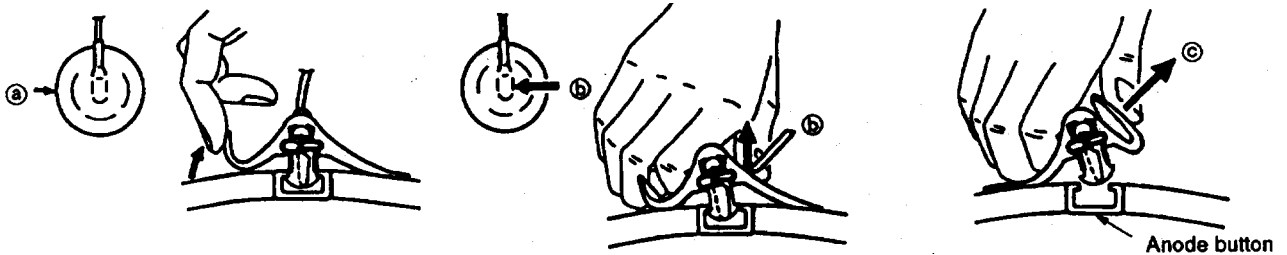

- ① Turn up one side of the rubber cap in the direction indicated by the arrow ②.
- ② Using a thumb pull up the rubber cap firmly in the direction indicated by the arrow ③.
- ③ When one side of the rubber cap is separated from the anode button, the anode-cap can be removed by turning up the rubber cap and pulling up it in the direction of the arrow ④.

#### • HOW TO HANDLE AN ANODE-CAP

- ① Don't hurt the surface of anode-caps with sharp shaped material!
- ② Don't press the rubber hardy not to hurt inside of anode-caps!  
A material fitting called as shatter-hook terminal is built in the rubber.
- ③ Don't turn the foot of rubber over hardy!  
The shatter-hook terminal will stick out or hurt the rubber.

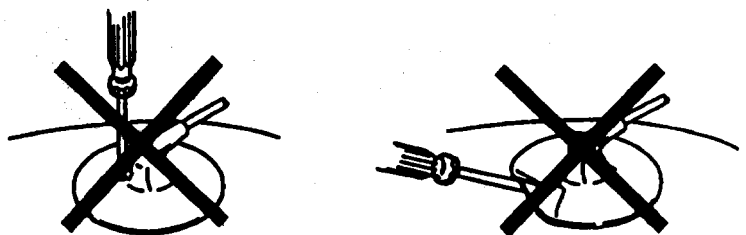

## SECTION 3 SET-UP ADJUSTMENTS

- The following adjustments should be made when a complete realignment is required or a new picture tube is installed.
- These adjustments should be performed with rated power supply voltage unless otherwise noted.

1. Beam Landing
2. Convergence
3. Focus
4. White Balance

**Note: Test Equipment Required.**

1. Color-bar Pattern Generator
2. Degausser
3. Digital multimeter

The control and switch below should be set as follows unless otherwise noted :

PICTURE control..... normal

BRIGHTNESS control..... normal

Perform the adjustments in order as follows:

### Preparation

- Feed in the white pattern signal.
- Before starting degauss the entire screen.

### 3-1. BEAM LANDING

1. Input a raster signal with the pattern generator.
2. Loosen the deflection yoke mounting screw, and set the purity control to the center as shown in Fig.2.
3. Turn the raster signal of the pattern generator to green.
4. Move the deflection yoke backward and adjust with the purity control so that green is in the center and red and blue are at the sides evenly. (Fig.3)
5. Move the deflection yoke forward and adjust so that the entire screen becomes green. (Fig.1)
6. Switch over the raster signal to red and blue and confirm the condition.
7. When the position of the deflection yoke is determined, tighten it with the deflection yoke mounting screw.
8. When landing at the corner is not right, adjust by using the disk magnets. (Fig.4)

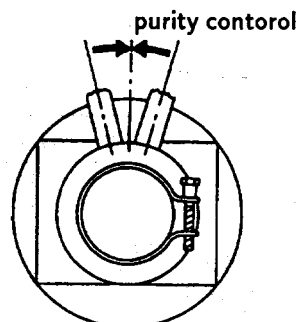

Fig. 2

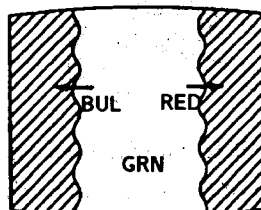

Fig. 3

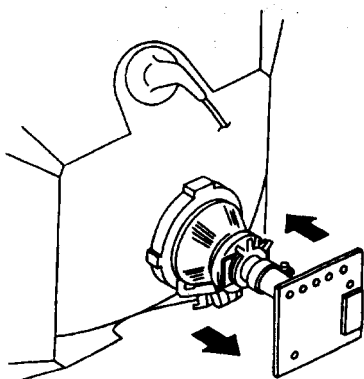

Fig. 1

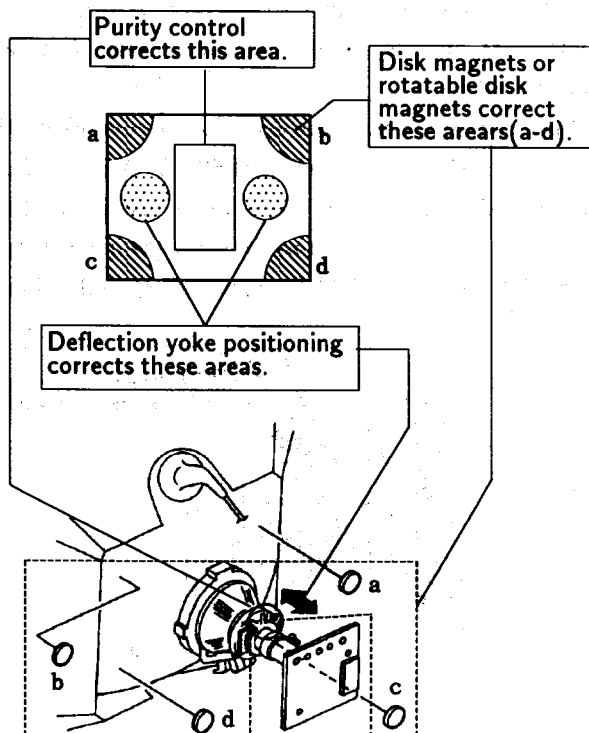

Fig. 4

### 3-2. CONVERGENCE

#### Preparation

- Before starting perform FOCUS, H.SIZE, V.LIN and V.SIZE adjustments.
- Set BRIGHTNESS control to minimum.
- Feed in dot pattern.

#### (1) Horizontal and Vertical Static Convergence

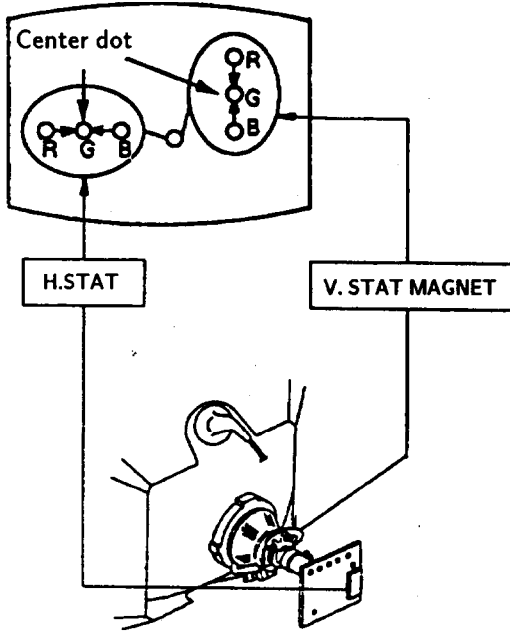

1. Adjust H.STAT VR to converge red, green and blue dots in the center of the screen. (Horizontal movement)
2. Adjust V.STAT magnet to converge red, green and blue dots in the center of the screen. (Vertical movement)
3. If the red, green and blue dots do not converge in the center of the screen with H.STAT VR, perform horizontal convergence adjustment using H.STAT VR and V.STAT magnet as shown below. (In this case, H.STAT VR and V.STAT magnet effect each other.)

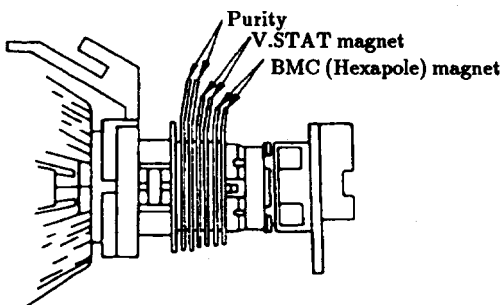

- Tilt the V.STAT magnet and adjust static convergence to open or close the V.STAT magnet.

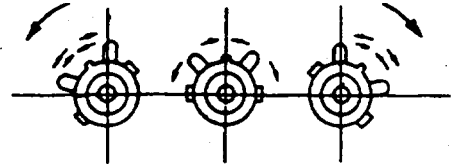

4. When the V.STAT magnet is moved in the direction of arrow (a) and (b), red, green and blue dots move as shown below.

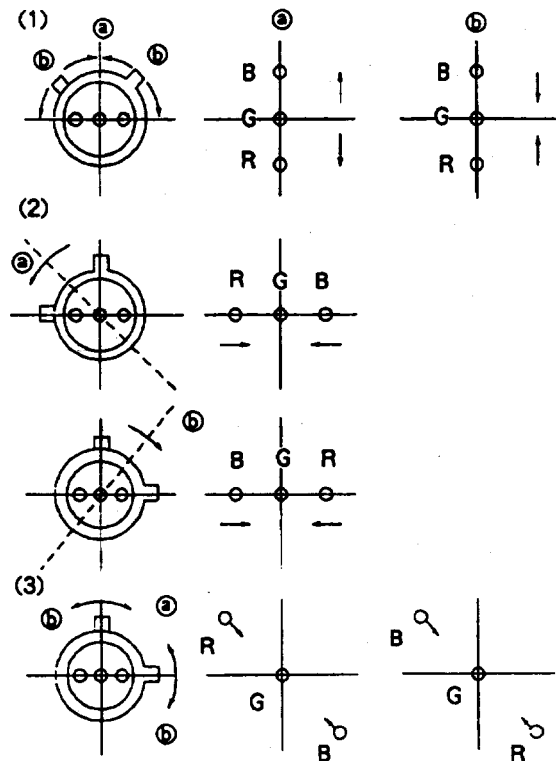

If the blue dot do not Converge with red and green dots, perform following steps.

- HMC and VMC correction for BMC (Hexapole) Magnet.

1. HMC (Horizontal Miss Convergence) correction and motion of the Electron Beam with the BMC Magnet.

HMC correction (A)

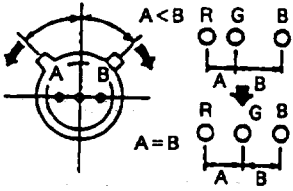

HMC correction (B)

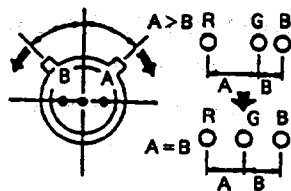

2. VMC (Vertical Miss Convergence) correction and motion of the Electron Beam with the BMC Magnet.

VMC correction (A)

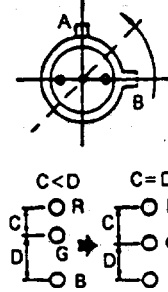

VMC correction (B)

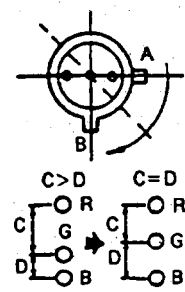

(2) Dynamic Convergence Adjustment Preparation

● Before starting perform Horizontal and Vertical static convergence Adjustmet.

1. Slightly loosen deflection yoke screw.
2. Remove deflection yoke spacers.

3. Move the deflection yoke for best convergence as shown below.

4. Tighten the deflection yoke screw.
5. Install the deflection yoke spacers.

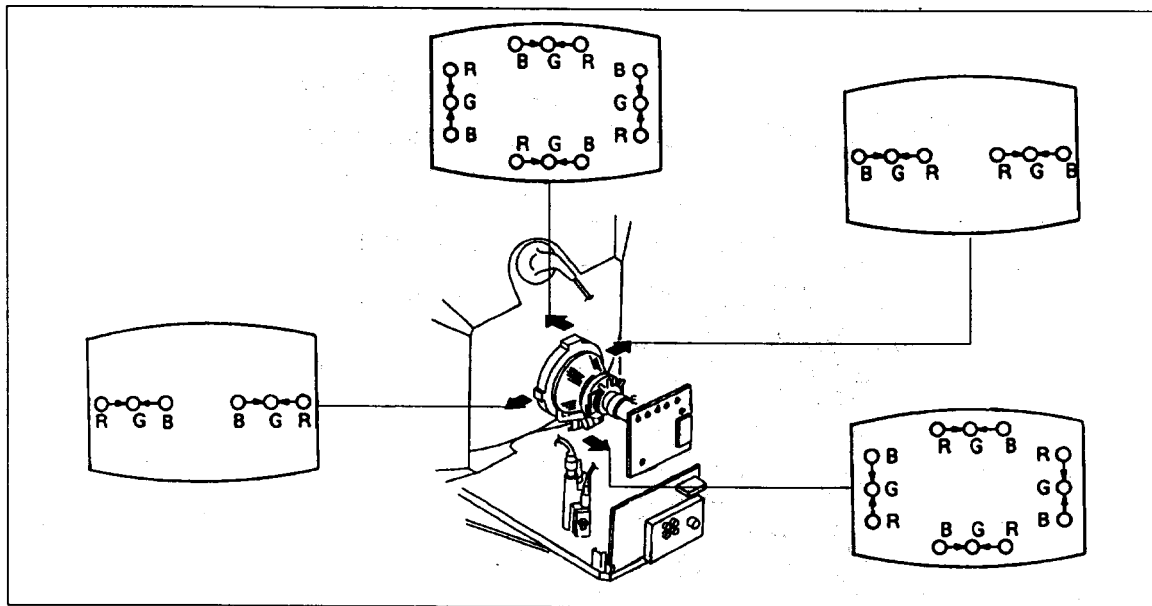

(3) Screen -corner Convergence

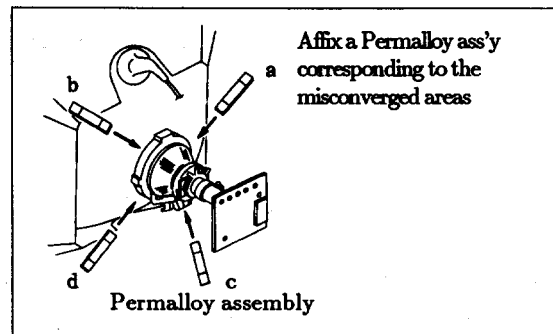
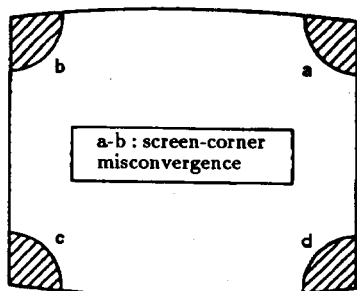

### 3-3. FOCUS

Adjust FOCUS control for best picture.

### 3-4. SCREEN(G 2) and WHITE BALANCE

#### [SCREEN(G2)]

1. Input dots pattern.
2. Set the PIC control at minimum and set the BRT control at maximum.
3. Confirm the BKG voltage is less than 180 Vdc when turning RV 706 (R.BKG), RV 704 (G.BKG) and RV 702 (B.BKG).
4. Note the color when becomes visible first when turning RV 708 (SCRN).

#### [WHITE BALANCE(Cut off)]

1. Input collar bar signl.
2. Set the PIC control to minimum and set the BRT control at normal.
3. Turn RV 703 (B.DRIVE) and RV 705 (G.DRIVE) fully clockwise.
4. Set RV 706 (R.BKG), RV 704 (G.BKG) and RV 702 (B.BKG) to minimum.
5. Turn RV 707 (SUB BRT) slowly to obtain a faintly visible blue stripe.
6. Switch over all white signal.
7. Adjust BKG controls for best white balance.
8. Set the PICTURE control to maximum. Observe the screen and adjust the DRIVE controls for best white balance.
9. Repeat steps 7 and 8.

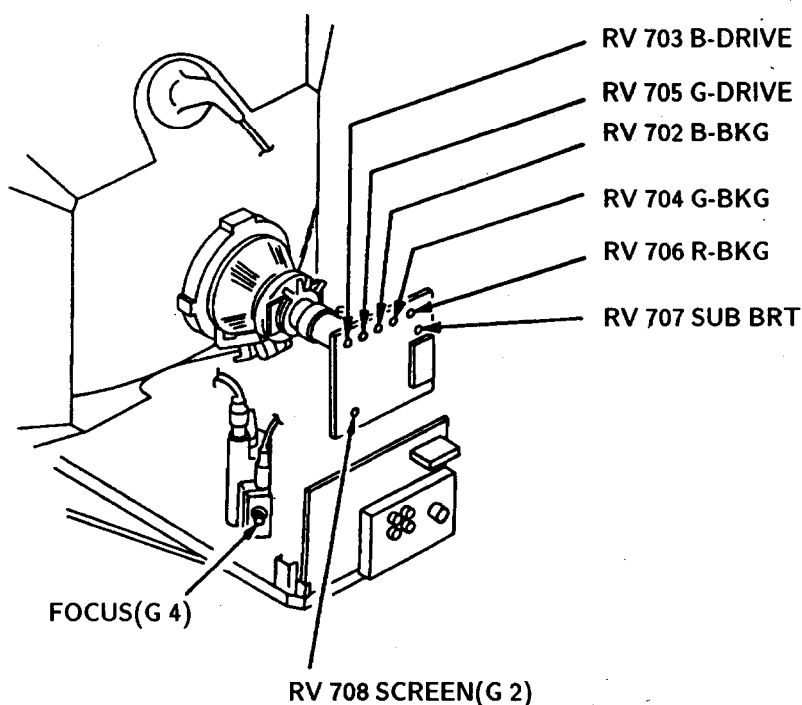

## SECTION 4 CIRCUIT ADJUSTMENTS

### 4-1. A BOARD ADJUSTMENTS

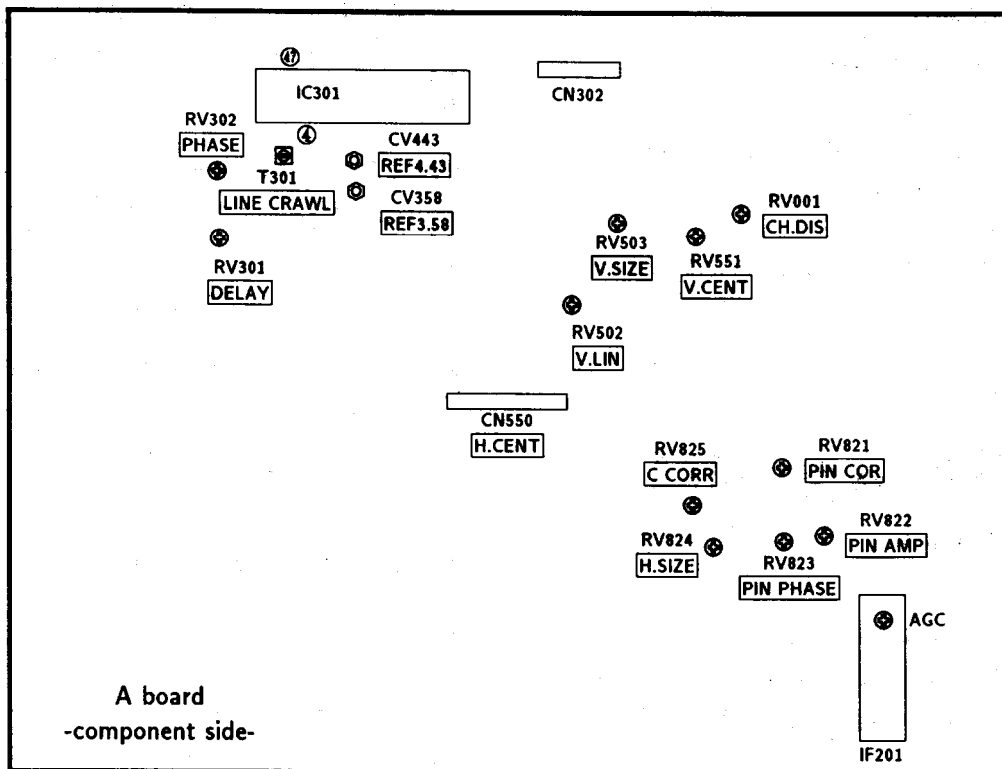

#### **RF AGC ADJUSTMENT (IF201)**

1. Receive a strong off-air signals.
2. Adjust RF AGC VR control so that snow noise and cross-modulation just disappear from the picture.

#### **Channel display POSITION ADJUSTMENT (RV001)**

1. Set PIC control to maximum.
2. Adjust RV001 so that the channel display should be positioned at up-right on the screen.

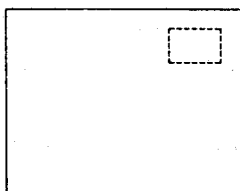

#### **A · P · C ADJUSTMENT (CV443) (PAL)**

1. Input the PAL color-bar signal.
2. Set the PIC, COL, and BRT controls to normal.
3. Short circuit between pin ④ and pin ④⑦ of IC301 with jumper.
4. Adjust CV443 for suitable color intensity.
5. Remove a jumper.

#### **REF OSC 3.58 ADJUSTMENT (CV358) (NTSC 3.58)**

1. Short circuit between pin ④ and pin ④⑦ of IC301 with a jumper.
2. Set the PIC, COL and BRT controls to normal.
3. Input NTSC 3.58 color-bar signal.
4. Adjust CV358 for suitable color intensity.
5. Remove the jumper.



**ANTI PAL, LINE CRAWLING ADJUSTMENT  
(RV301,RV302,T301)**

• ANTI PAL ADJUSTMENT

1. Input PAL color-bar signal.
2. Set the PIC, COL and BRT controls to normal.
3. Connect the oscilloscope to pin ③ of CN302 connector.
4. Adjust RV301 (DELAY) and RV302 (PHASE) to obtain the waveform as shown below.

• LINE CRAWLING ADJUSTMENT

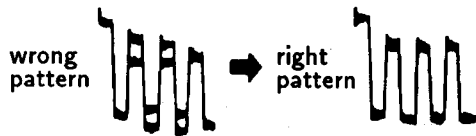

1. Input the PAL color-bar signal.
2. Set the PIC, COL and BRT controls to normal.
3. Connect the oscilloscope to pin ③ of CN302 connector.
4. Adjust T301 for minimum line crawling.

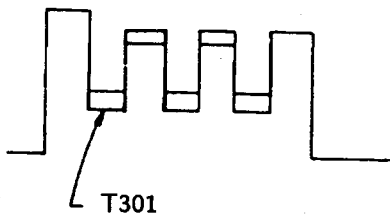

**RV822 PIN ANP (PINCUSHION AMPLIFIER)**

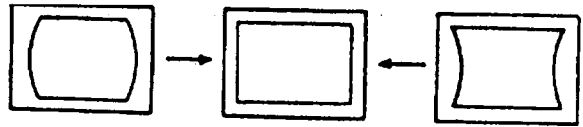

**RV823 PIN PHASE (PINCUSHION PHASE)**

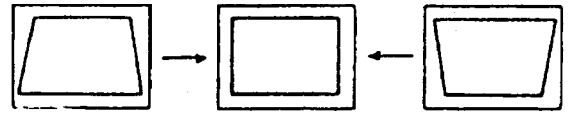

**RV821 PIN COR (PINCUSHION CORRECT)**



**RV825 C.CORR (CORNER CORRECT)**

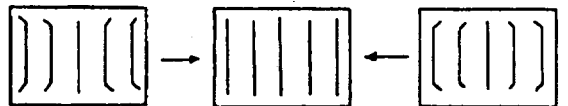

**RV824 H.SIZE (HORIZONTAL SIZE)**



**RV503 V.SIZE (VERTICAL SIZE)**

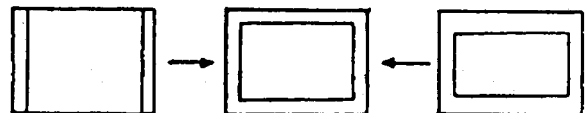

**RV502 V.LIN (VERTICAL LINEARITY)**

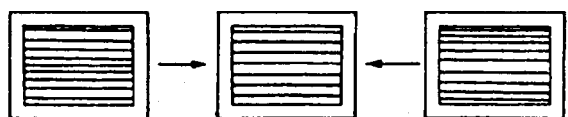

**CN550 H.CENT (HORIZONTAL CENTER)**

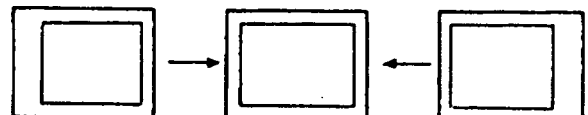

**RV551 V.CENT (VERTICAL CENTER)**



5-2. CIRCUIT BOARDS LOCATION

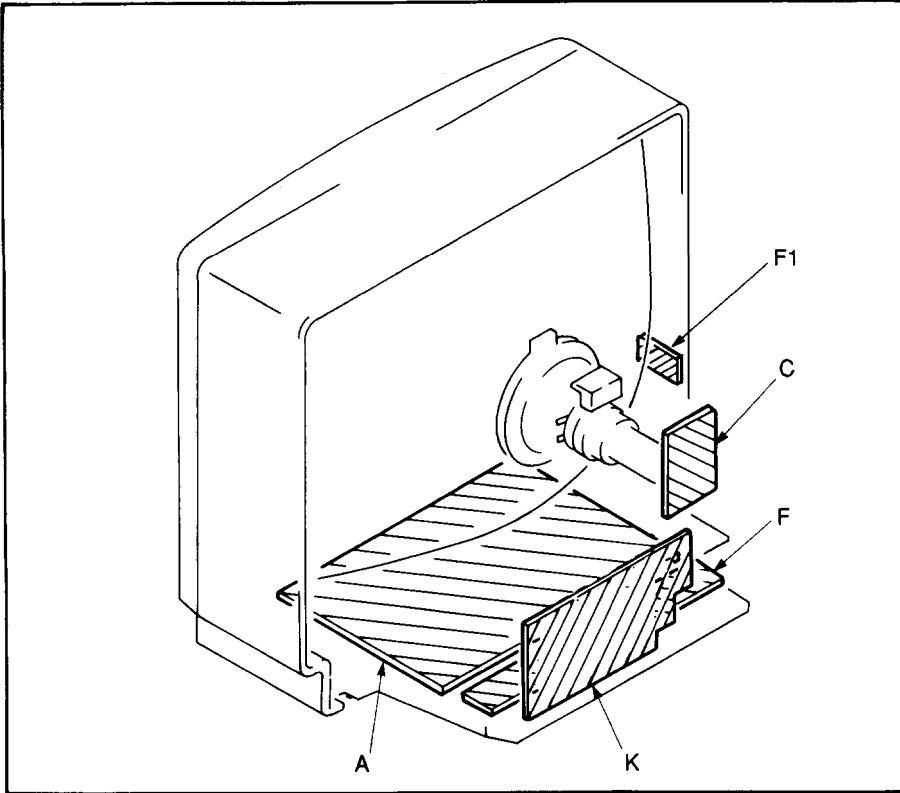



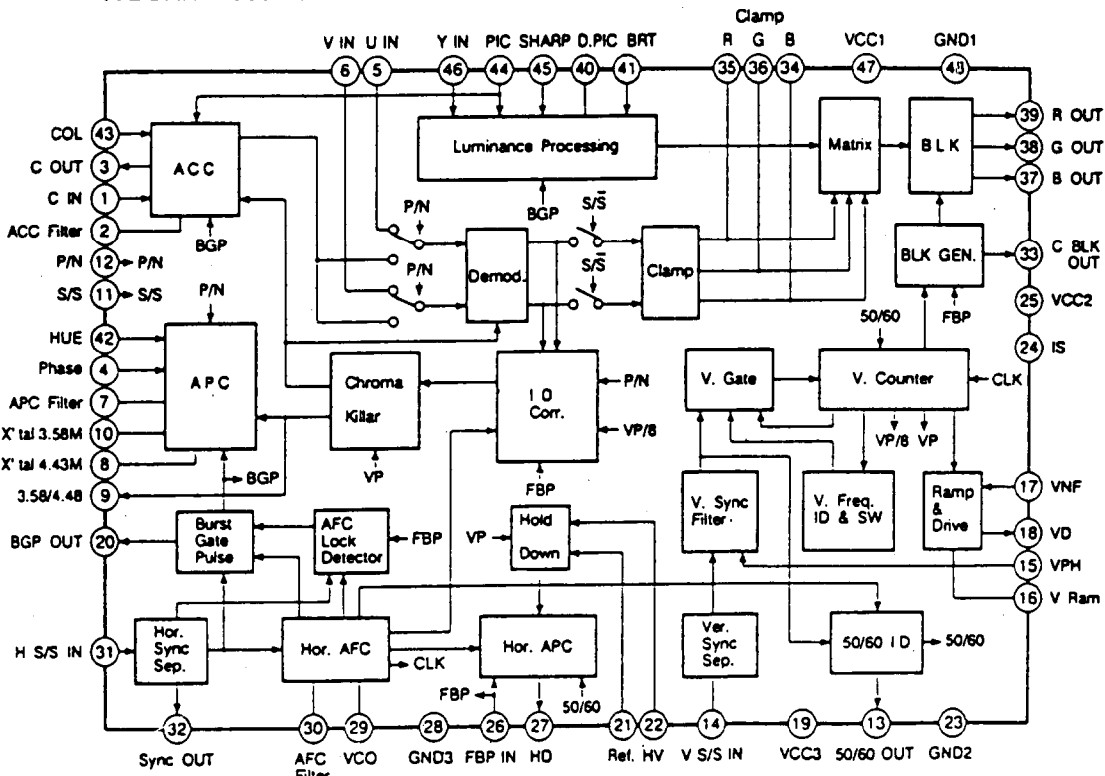

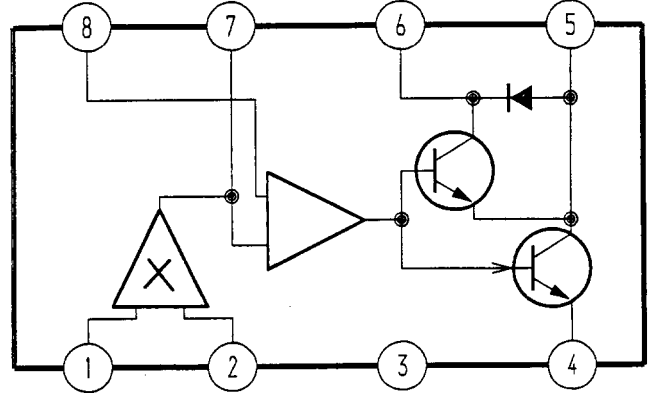

A BOARD IC301 CXA1213S



A BOARD IC821 TEA2031A



**K BOARD WAVEFORMS**

<p>①</p>  <p>1.0Vp-p (H)</p>	<p>②</p>  <p>1.0Vp-p (H)</p>	<p>③</p>  <p>2.0Vp-p (H)</p>
<p>④</p>  <p>2.0Vp-p (H)</p>	<p>⑤ PAL/NTSC</p>  <p>0.6Vp-p (H)</p>	<p>⑥</p>  <p>1.5Vp-p (H)</p>
<p>⑦ PAL/NTSC</p>  <p>1.0Vp-p (H)</p>		

5-4. SEMICONDUCTORS

CXA1213S

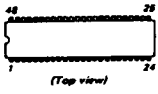

MC14052BCP  
MC14049UBCP  
TDA8444  
μ PD4053BC

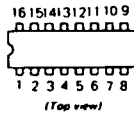

TA8662N

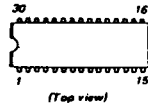

DTA114ES  
DTC114ES  
DTC124ES  
DTC143TS  
DTC144ES  
2SC3327-A



2SC2216



CXK5864BSP-10L  
MC14066BCP  
MC33079P  
SAA5231-A6

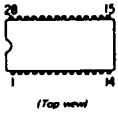

PCA84C840P/054  
TC6011N

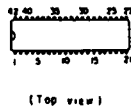

TDA2007

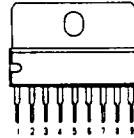

2SA1175-HFE  
2SC2785-HFE  
2SC3311A



2SC4927-01

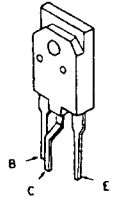

KEY-C00SV-F

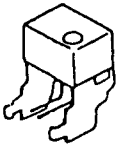

RC78L09A



TD6710AN

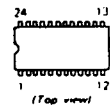

2SA1220A-P  
2SC2611  
2SC2688-LK

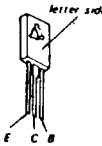

2SD1408-Y



LA7016

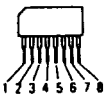

RC7812FA

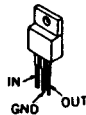

μ PC1498H

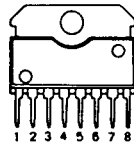

2SA1221-L  
2SB734-34  
2SC2958-L  
2SD774-34

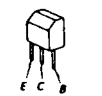

2SD1761



LM393P  
RC4558P  
ST24C02AB1  
TEA2031A

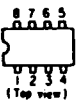

SAA5243P/E/M3

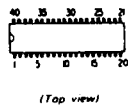

μ PC574J

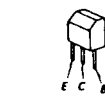

2SK669



LM1036N

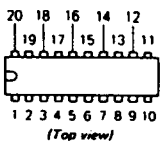

STR-S5741

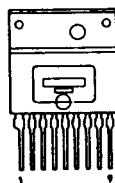

μ PC7893HF

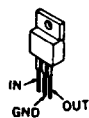

2SA1306A-Y  
2SC3298B-Y

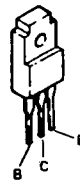

D4SB60L-F

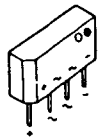

L78LR05D-MA

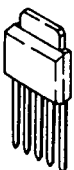

**D5LC20U**

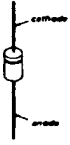

**MC932**

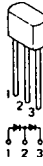

**EGP30GL-6072**  
**ERC06-15S**  
**RU-1P**  
**RU-3AM**

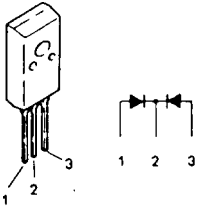

**RD10ES-B2**  
**RD10ES-B3**  
**RD13ES-B2**  
**RD13ES-B3**  
**RD39ES-B2**  
**RD5.1ES-B2**  
**RD5.6ES-B2**  
**RD6.2ES-B2**  
**RD6.8ES-B3**  
**RD7.5ES-B1**  
**RD7.5ES-B3**  
**RD9.1ES-B1**  
**RD9.1ES-B2**  
**RD9.1ES-B3**  
**1SS119**

**ERD29-08J**  
**RU4DS**

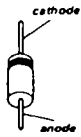

**EU2Z**  
**ES1F-N**  
**R2K**  
**WG713A**



**RD10SB1**

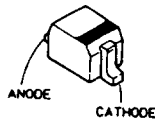

**U05G**

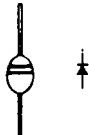

**MC911**



**SEL1222R-C**

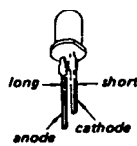

**MC921**



# 6-1. CHASSIS

● : BVTP3×12 7-685-648-79

■ : BVTP4×16 7-685-663-79

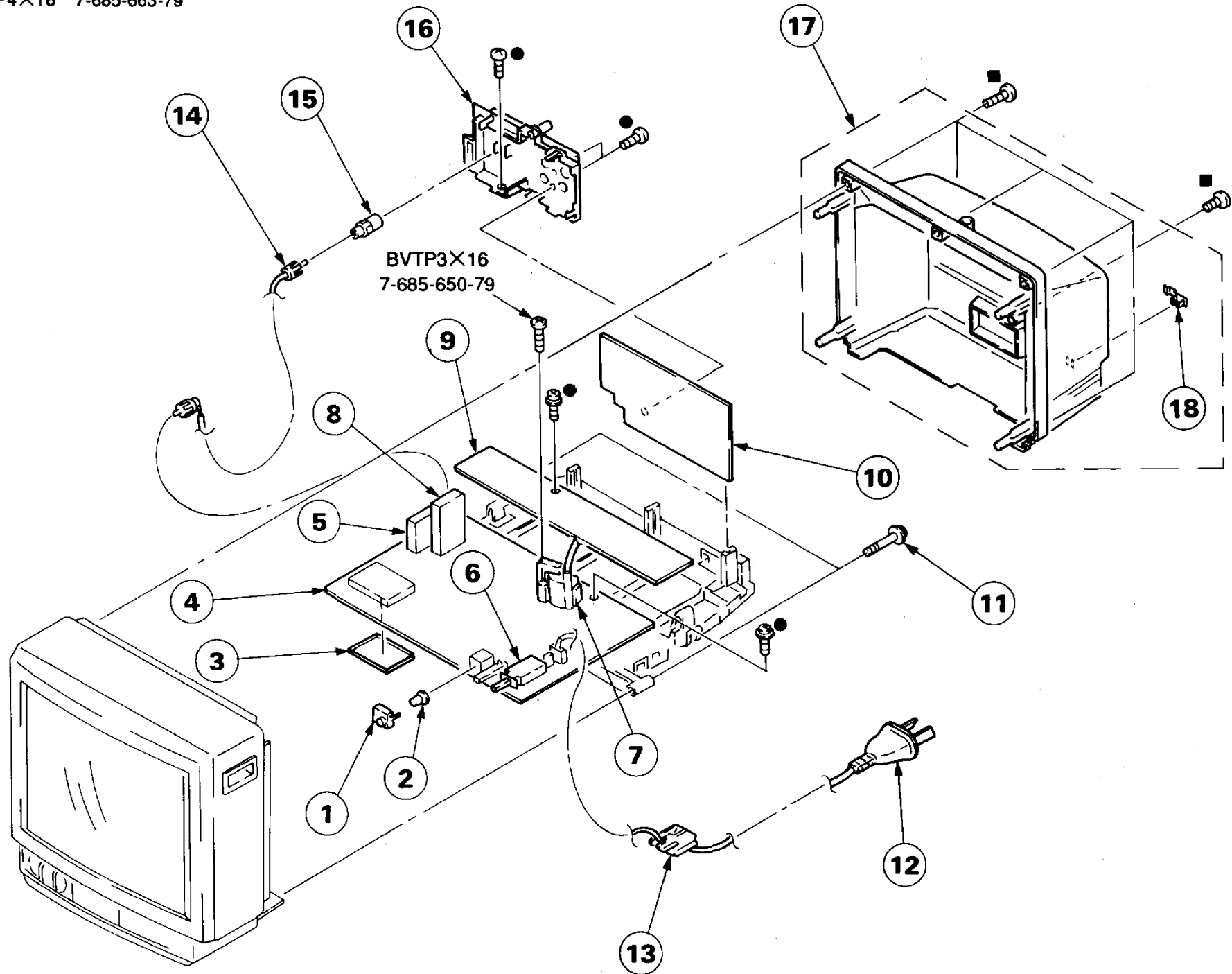

6-2. PICTURE TUBE ● : BVTP3X12 7-685-648-79

▲ : BVTP3X8 7-685-646-79

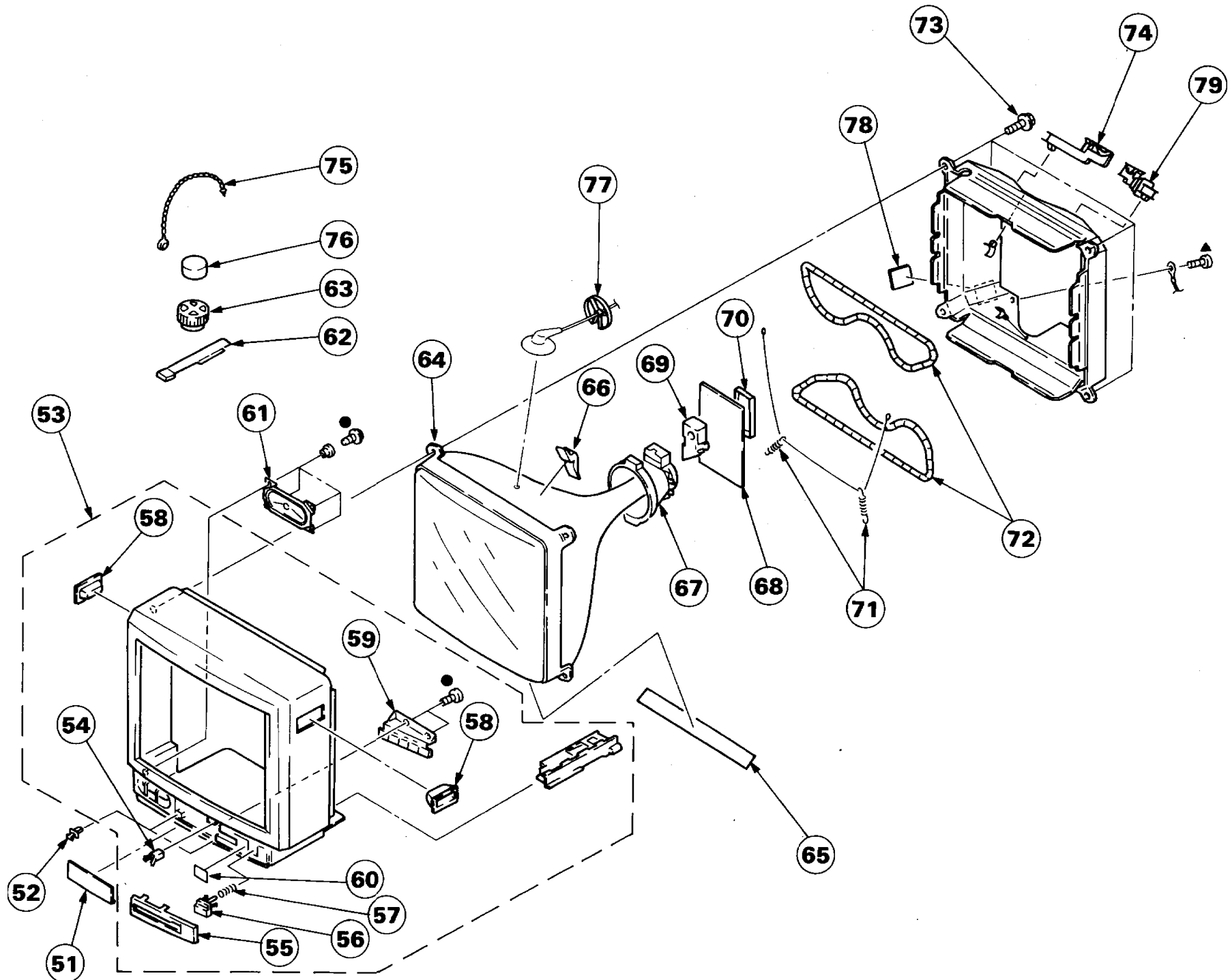



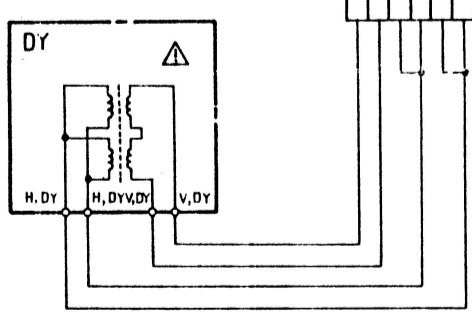
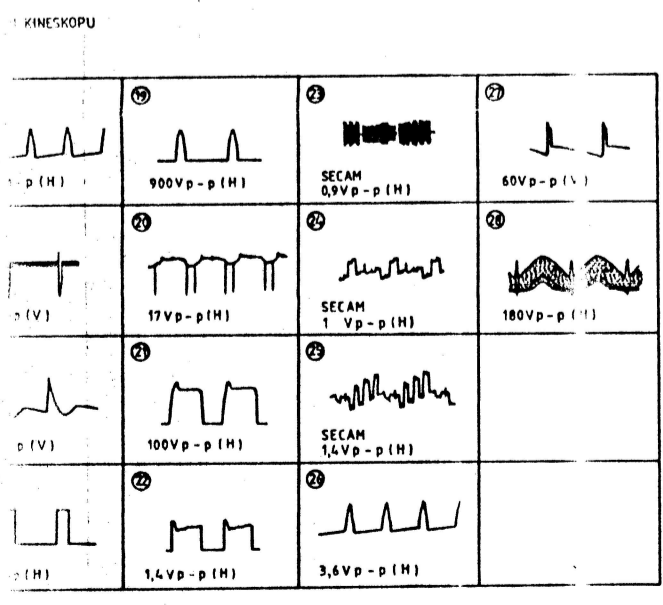
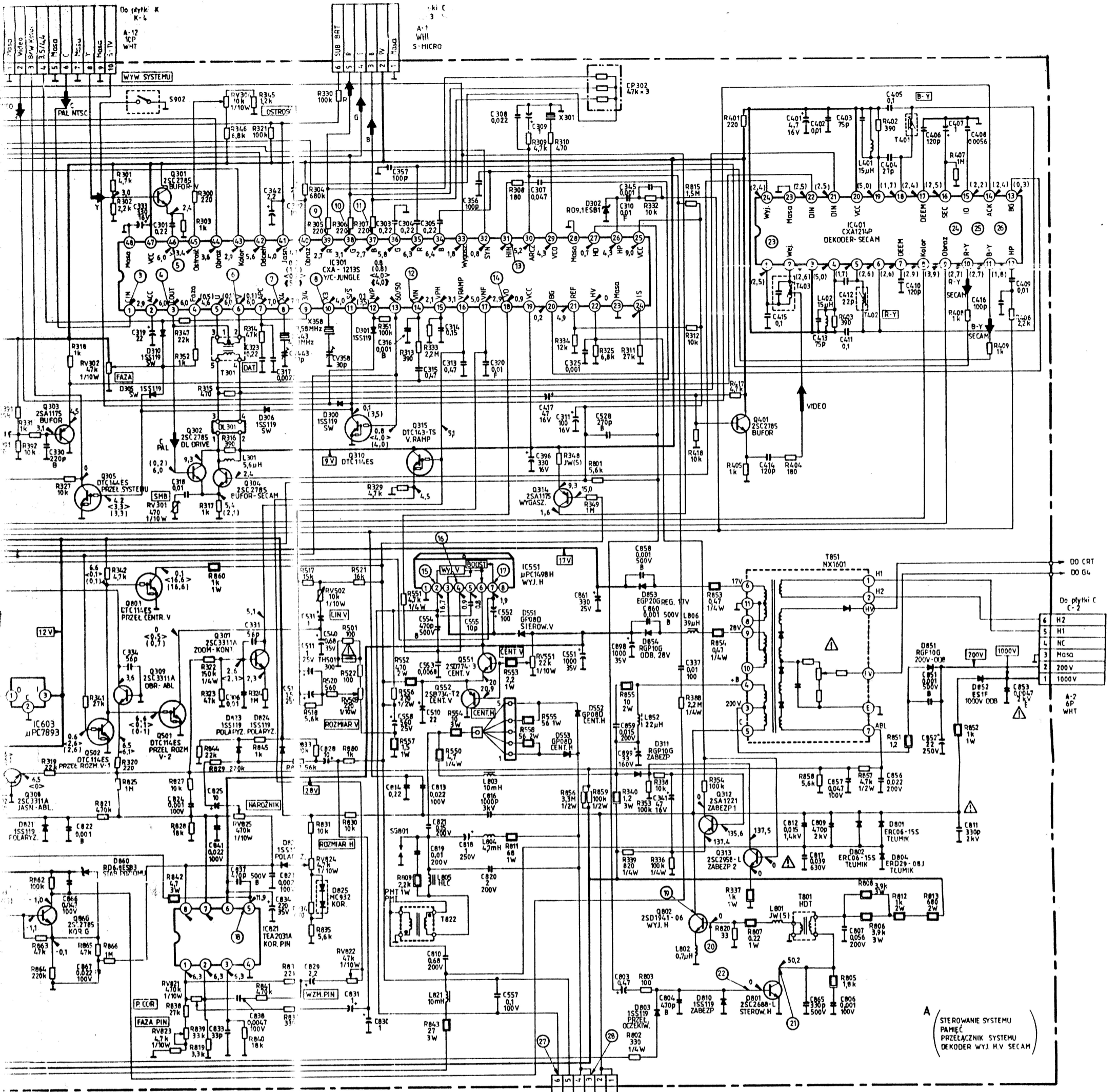

UWAGA:  
SURROUND - efekt przestrzennego  
poszerzenia barwy dźwięku

A  
STEROWANIE SYSTEMU  
PAMIĘĆ PRZEŁĄCZNIK SYSTEMU  
DEKODER WYJ. H.V. SECAM

PASMO	VHF DOLNY	VHF WYSOKI	UHF
7 (VL)	+12V		
8 (VH)		+12V	
10 (U)			+12V
11 (VC)	1.3V - 22.0V	9.5V - 23.5V	2.0V - 26.5V
6 (LBI)		+12V	
5 (ARW)	8.5 (WZMOC MAX) - 0.3V		

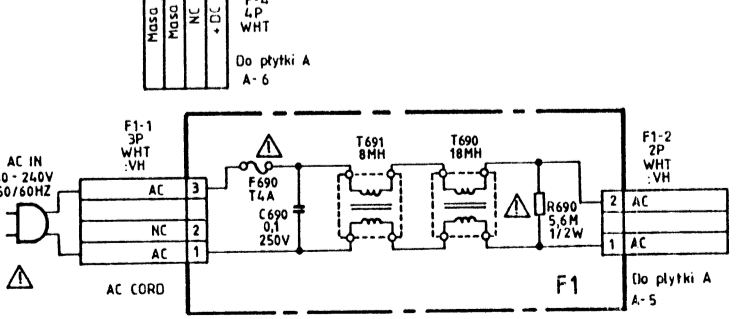
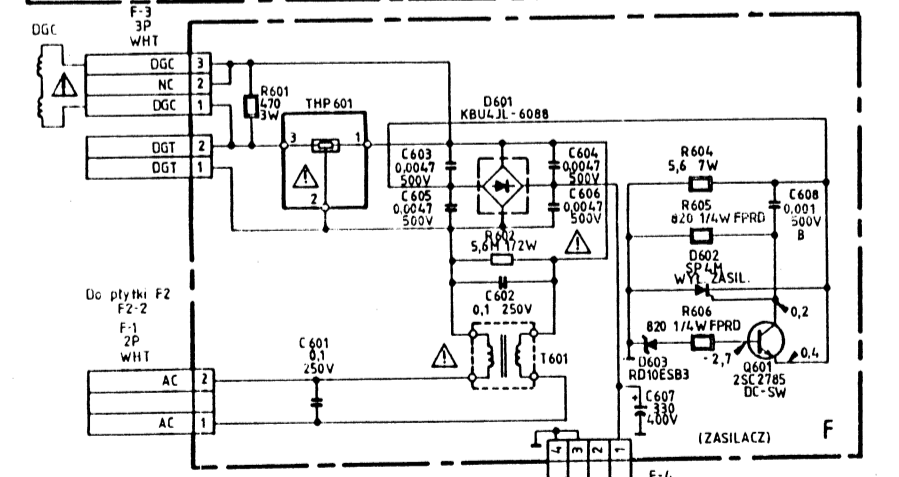
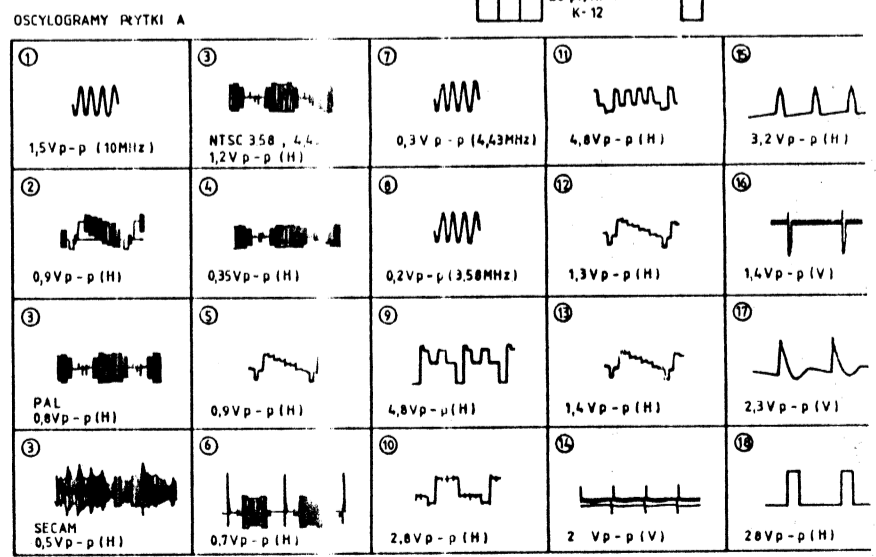
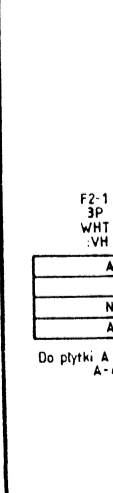
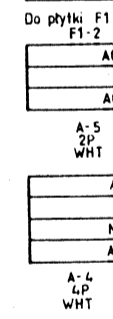
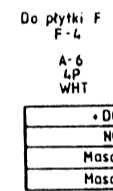
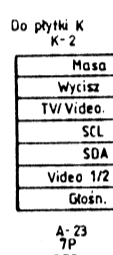
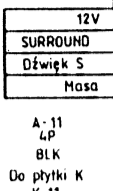
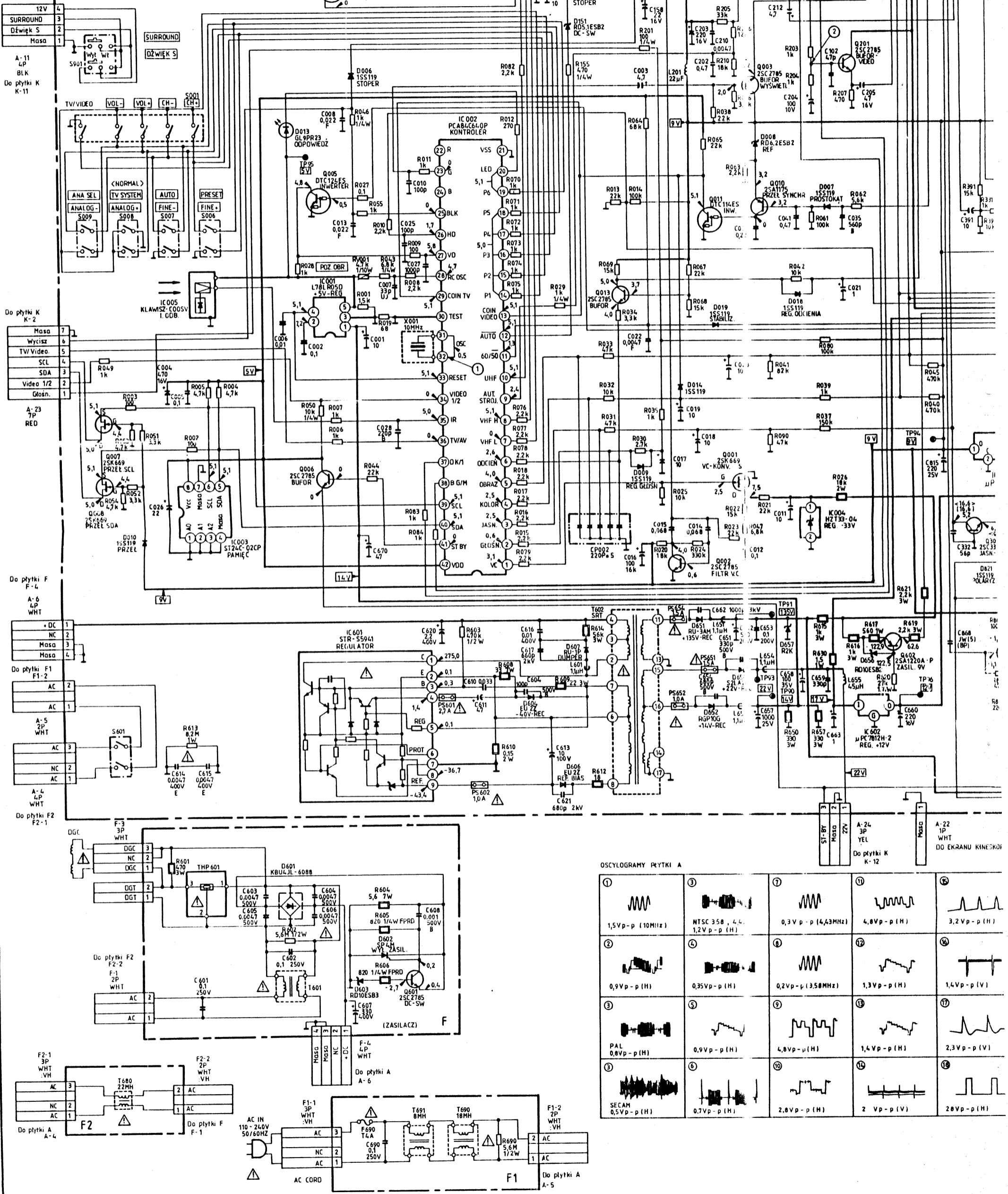

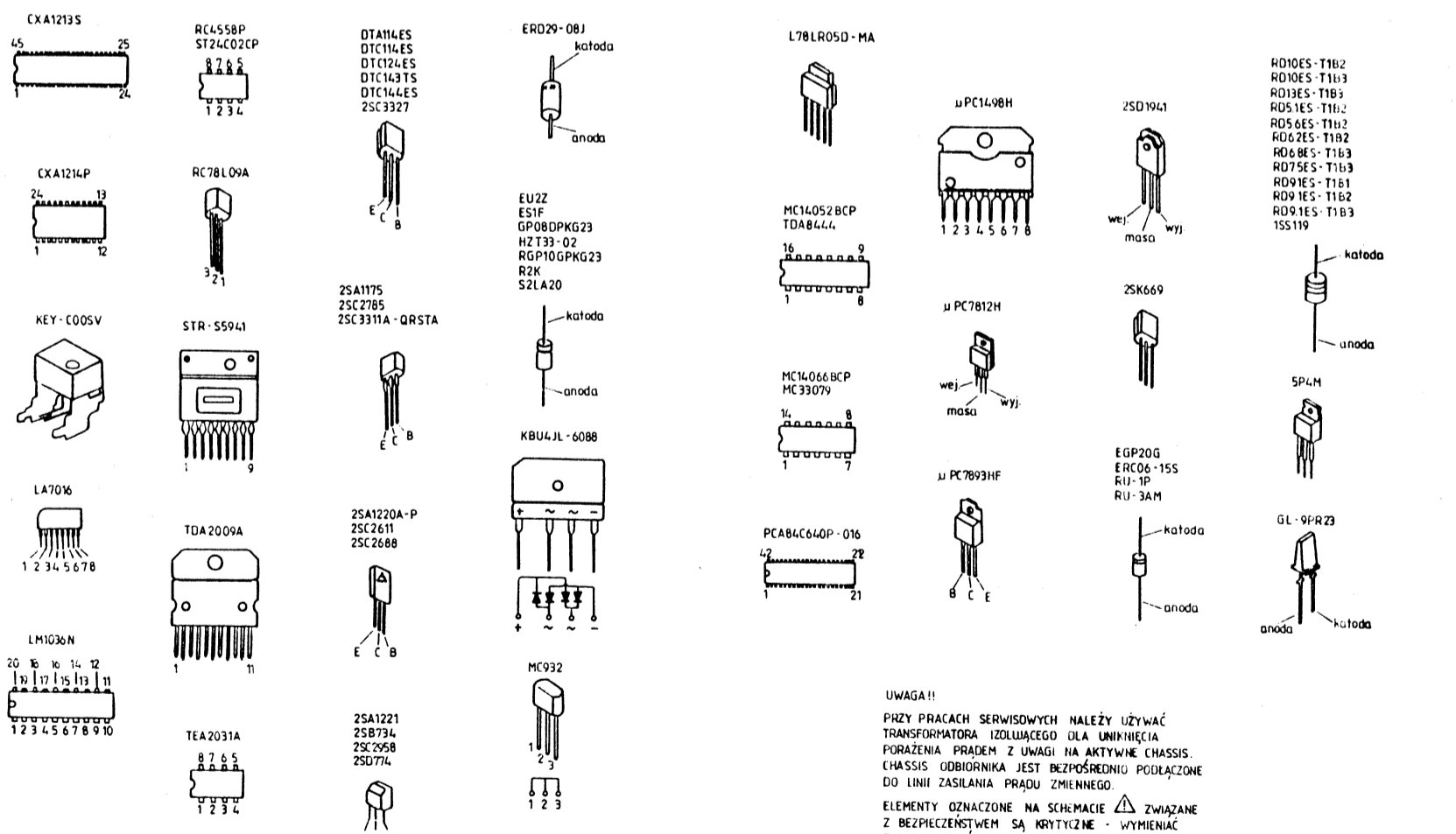
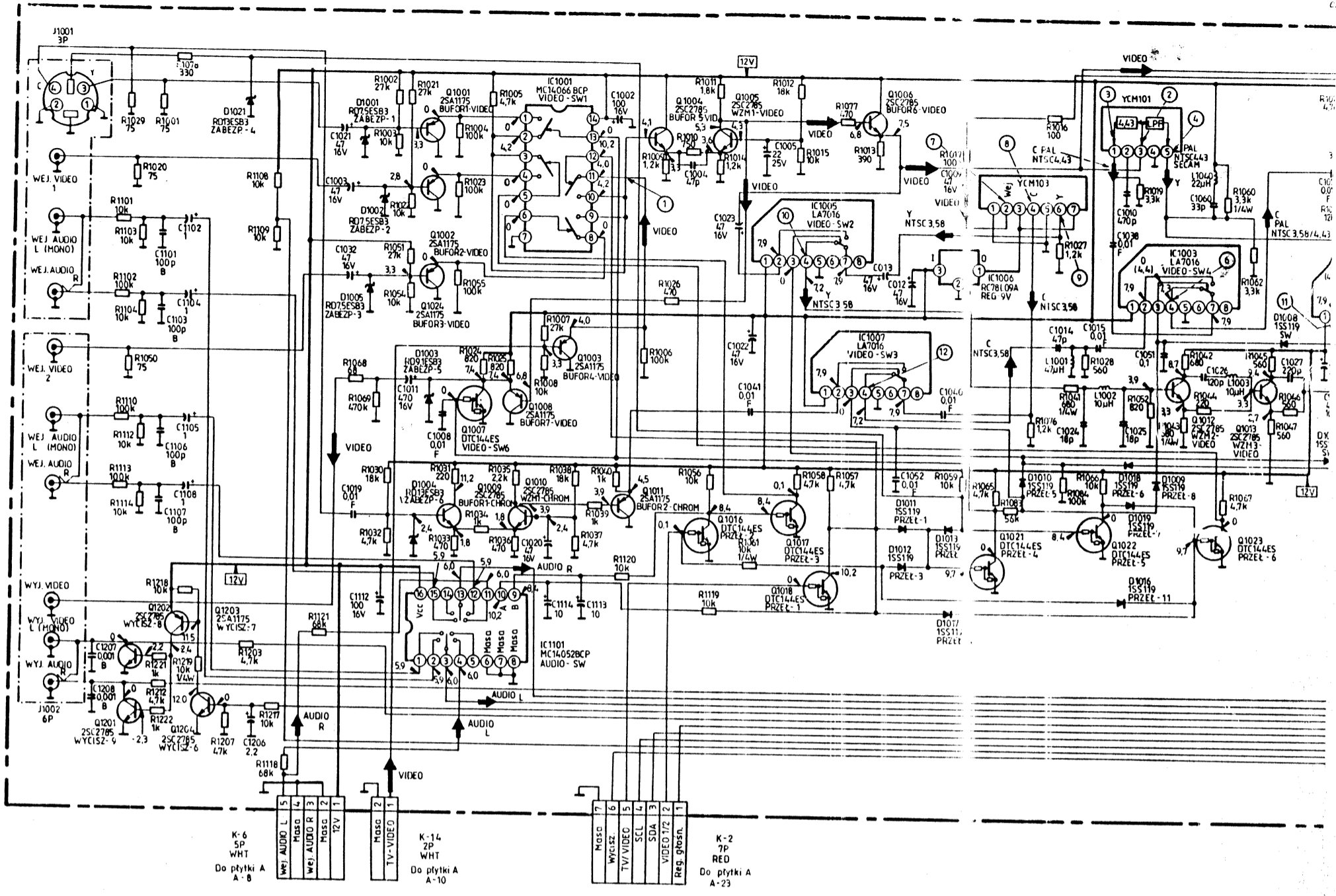

UWAGA!!  
 PRZY PRACACH SERWISOWYCH NALEŻY UŻYWAĆ TRANSFORMATORA IZOLUJĄCEGO DLA UNIKNIĘCIA PORAZENIA PRĄDEM Z UWAGI NA AKTYWNE CHASSIS. CHASSIS ODBIORNIKA JEST BEZPOŚREDNIO PODŁĄCZONE DO LINII ZASILANIA PRĄDU ZMIENNEGO.  
 ELEMENTY OZNACZONE NA SCHEMACIE ZWIĄZANE Z BEZPIECZEŃSTWEM SĄ KRYTYCZNE - WYMIENIĆ TYLKO NA CZĘŚCI SONY O PODANYCH OZNACZENIACH

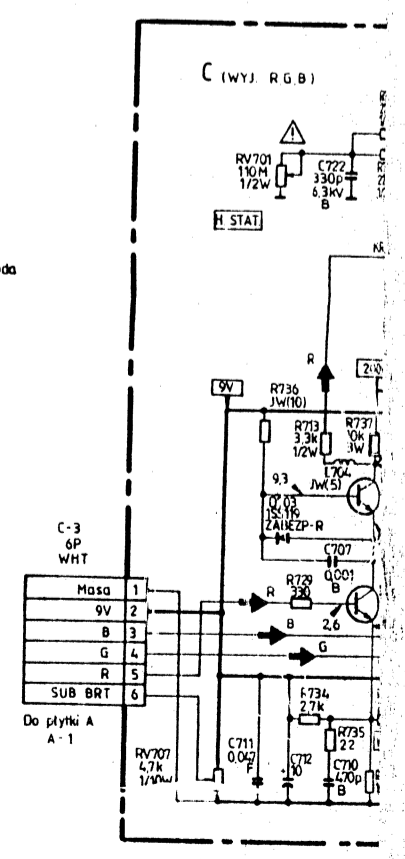



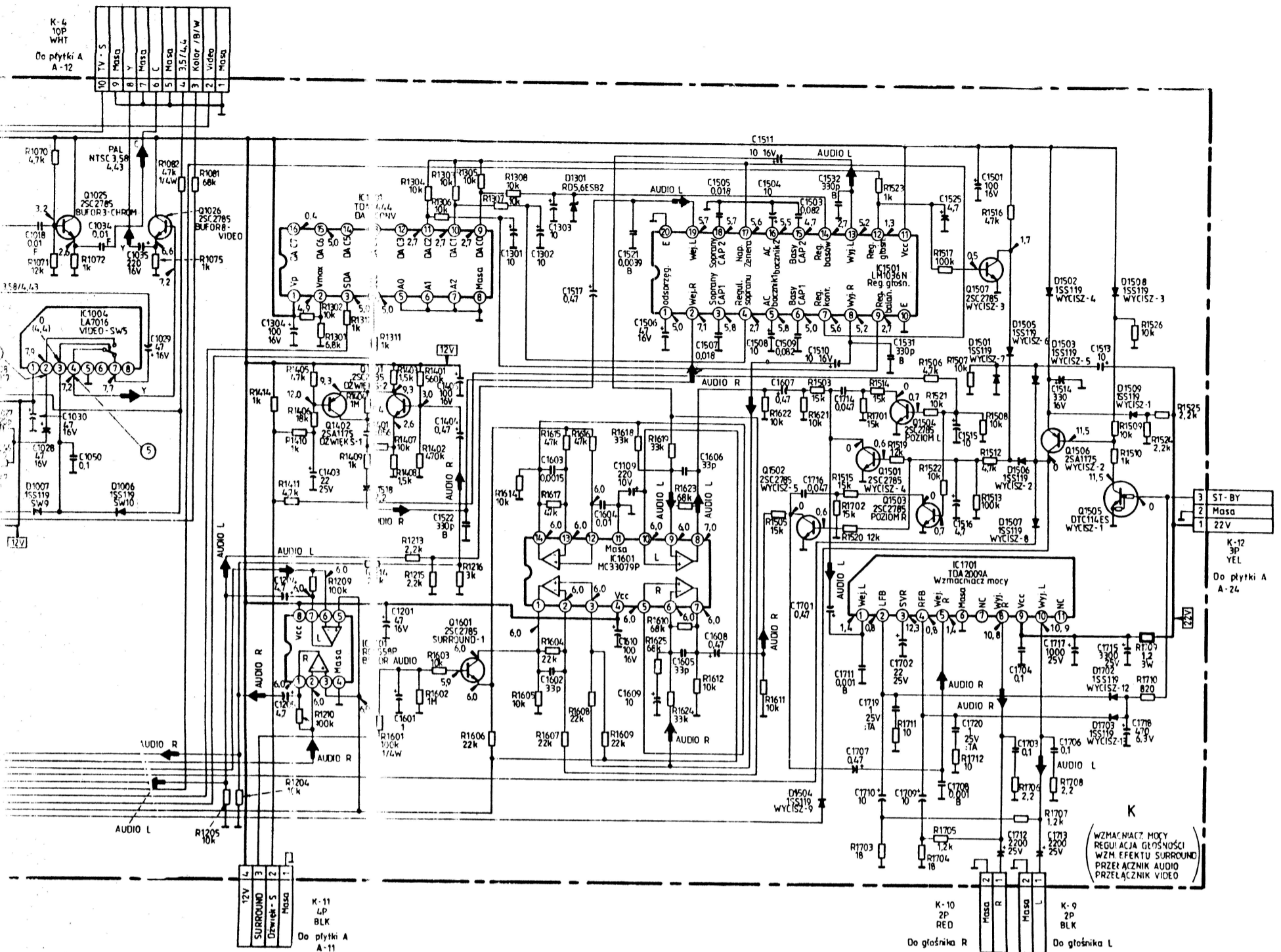

**UWAGI:**

Wszystkie kondensatory są w  $\mu\text{F}$ , jeżeli nie zaznaczono inaczej.  
 Napięcie pracy poniżej 50V nie oznaczono za wyjątkiem elektrolitów.  
 Rezystory, które nie mają oznaczenia mocy należy traktować:  
 k $\Omega$ : 1000 $\Omega$ , M $\Omega$ : 1000k $\Omega$ .  
 Jeżeli nie zaznaczono inaczej, wszystkie rezystory zmienne i regulacyjne mają charakterystykę B

rezystor nieadjustable  
 rezystor bezpiecznikowy  
 regulacja serwisowa  
 B + bus  
 ścieżka sygnału

Napięcia są stałe w odniesieniu do masy, jeżeli nie zaznaczono inaczej.  
 Pomiar przeprowadzono multimetrem cyfrowym 10Ma.  
 Dopuszczalne są wahania napięć z uwagi na tolerancje produkcyjne.  
 Pomiar przeprowadzono przy sygnale wejściowym: pasy kolorowe bez oznaczenia: odbiór sygnału pasów kolorowych PAL  
 SECAM  
 NTSC 4,43  
 NTSC 3,58

**OSCYLOGRAMY PŁYTKI K**

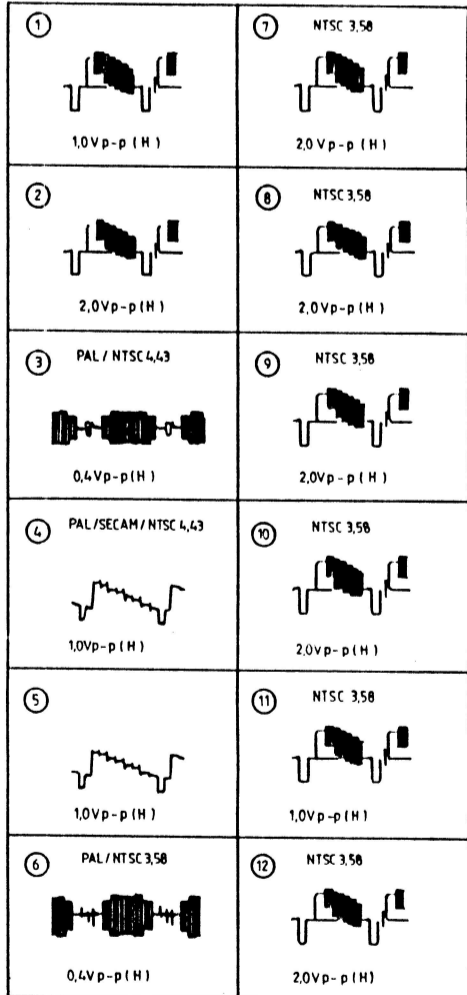

**OSCYLOGRAMY PŁYTKI C**

